



**MODBUS
I/O Modules**

Modbus RTU Series

Standard Signal AI Module

DMB 96100

Measuring input for Standard Signals, Modbus RTU

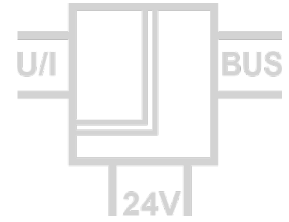

The Modbus Standard Signal AI Module is used for electrical isolated conversion of unipolar standard voltage and current signals. A transmitter power supply is provided for the operation of 2-wire and 3-wire transmitters.

All parameters can be set via the Modbus RTU interface and via a programming socket behind the front panel. A free PC configuration software also offers extended setting options and extensive diagnostic functions during operation. A subset of the most common settings is also available via DIP switches.

The measuring value can be read over the Modbus RTU (RS485) interface.

The 2-way isolation guarantees reliable decoupling of the sensor circuit from the processing circuit and the auxiliary power circuit. Auxiliary power and Modbus RTU can be connected via the connection terminals or via the In-Rail-Bus connector (see accessories).

- **Input for industrial standard signals**
current and voltage signals and transmitter supply
- **In-Rail-Bus Connector for Modbus and Power Supply**
allows fast and economical installation
- **Protective Separation up to 300 V AC/DC**
test voltage 3 kV
- **Easy configurable**
via DIP switches or Modbus interface
- **Freely scalable**
up to 247 DRAGO modules in one Modbus segment
- **Extremely slim design**
6.2 mm slim housing for a simple and space saving DIN rail mounting
- **5 Years Warranty**
Defects occurring within 5 years from delivery date shall be remedied free of charge at our plant (carriage and insurance paid by sender)



Block Diagram

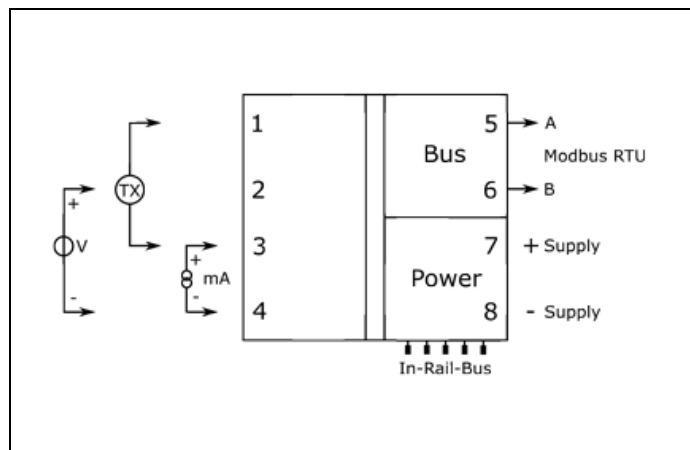

Technical Data

Input	Voltage	Current
Input signal	0 to 10 V	0 to 20 mA
Input resistance	≥ 100 kΩ	≤ 25 Ω
Overload	≤ 30 V	≤ 50 mA
Transmitter supply	16 V (open circuit/short circuit < 22 V / 35 mA)	
Modbus		
Protocol	Modbus RTU (RS485)	
Module addressing	1 to 247	
Response delay	1 to 1000 ms	
Baud rate	300, 600, 1200, 2400, 4800, 9600, 19200, 38400, 57600, 115200	
Configuration	Parity: Even, Odd, None 2 stop bits, None 1 stop bit	
Connectivity	Up to 247 DRAGO Modbus devices without additional repeater (1/8 Load)	
Indication	Yellow LED on front panel	
Measuring range	0 to 115 %	
General Data		
Measuring error	< 0.1 % full scale	
Temperature coefficient ¹⁾	< 100 ppm/K	
Resolution	14 bit	
Sampling rate	up to 100/s (a moving average filter with a width of 10 samples is applied internal)	
Test voltage	3 kV AC, 50 Hz, 1 min. Input against Modbus/power supply	
Working voltage ²⁾ (Basic insulation)	600 V AC/DC for overvoltage category II and pollution degree 2 acc. to EN 61010-1	
Protection against dangerous body currents ²⁾	Protective Separation by reinforced insulation acc. to DIN EN 61010-1 up to 300 V AC/DC for overvoltage category II and contamination class 2 between input and Modbus/power supply	
Ambient temperature	Operation: -25 °C to +70 °C (-13 to +158 °F) Transport and storage: -40 °C to +85 °C (-40 to +185 °F)	
Power supply	24 V DC voltage range 16.8 V to 31.2 V DC, max. 1.3 W	
EMC ³⁾	EN 61326-1	
Construction	6.2 mm (0.244") housing, protection type: IP 20, mounting on 35 mm DIN rail acc. to EN 60715	
Weight	Approx. 70 g	

1) Average TC related to full scale in specified operating temperature range, reference temperature 23 °C

2) For applications with high working voltages, ensure there is sufficient spacing or isolation from neighboring devices and protection against electric shocks.

3) Minor deviations possible during interference

Dimensions

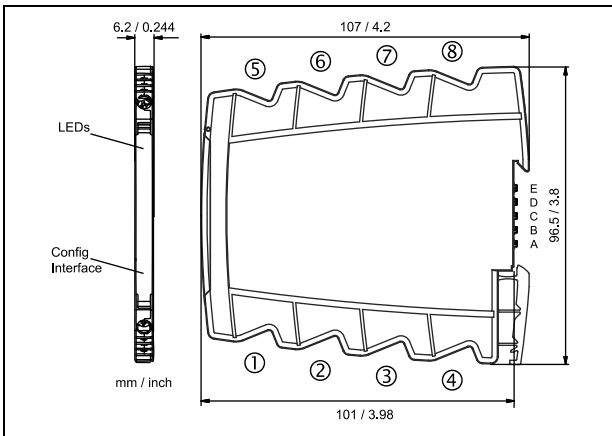

Subject to change!

Terminal assignments

1	+ Transmitter Supply Tx	
2	+ Input U	
3	+ Input I	
4	- Input GND	
5	Modbus A	(connected to In-Rail-Bus A)
6	Modbus B	(connected to In-Rail-Bus B)
7	+ Power supply	(connected to In-Rail-Bus D)
8	- Power supply	(connected to In-Rail-Bus C)

Connection

Captive plus-minus clamp screws
 Wire cross-section 0.5 ... 2.5 mm² / AWG 20-14
 Stripped length 8 mm / 0.3 in
 Screw terminal torque 0.6 Nm / 5 lbf in
 Optional power connection via In-Rail-Bus (see accessories)

Product line

Device	Order No.
Modbus Standard Signal AI Module	DMB 96100 B

4 Channel AI Module

DMB 96200

4 Fully Isolated Analog Inputs, Modbus RTU

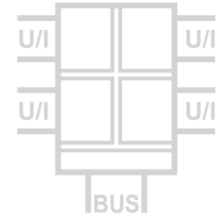

The Modbus 4 Channel AI Module provides four fully isolated, independently configurable inputs. Each input can be configured as either a current input or a voltage input. Various filter functions can be used to suppress interferences.

All parameters can be set via the Modbus RTU interface and via a programming socket behind the front panel. A free PC configuration software also offers extended setting options and extensive diagnostic functions during operation. A subset of the most common settings is also available via DIP switches.

The 5 port isolation ensures reliable decoupling of the inputs from each other and from the processing circuit and the power supply. Power supply and Modbus RTU are connected via the rear-mounted In-Rail-Bus connection (see Accessories).



- **Acquisition of 4 industrial standard signals**
individually configurable as current or voltage input
- **4 galvanic isolated inputs**
protection against erroneous measurements due to parasitic voltages or ground loops
- **Protective 5 port separation up to 300 V AC/DC**
Test voltage 3 kV
- **Fast signal acquisition**
high measuring rate, short processing times
- **In-Rail-Bus connector for Modbus and Power Supply**
allows fast and economical installation
- **Freely scalable**
up to 247 DRAGO Module in one Modbus segment
- **Extremely slim design**
6.2 mm slim housing for a simple and space saving DIN rail mounting
- **5 Years Warranty**
Defects occurring within 5 years from delivery date shall be remedied free of charge at our plant (carriage and insurance paid by sender)

Block diagram

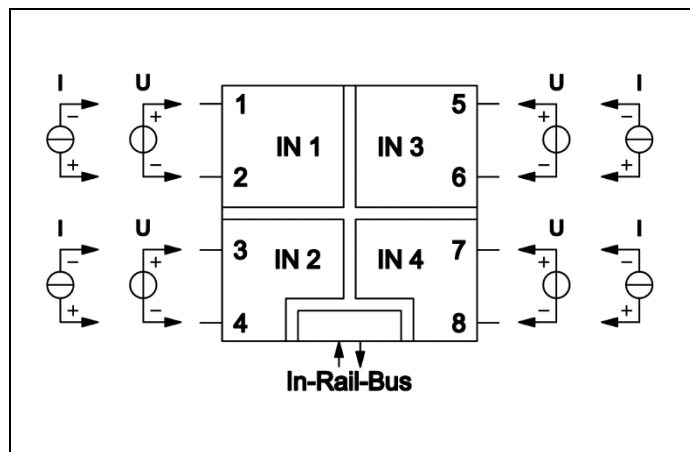



Technical Data

Input	Voltage	Current
Input signal	0 to 10 V	0 to 20 mA
	4 channels, common selectable via DIP switch, individual configurable by software	
Input resistance	$\geq 100 \text{ k}\Omega$	$\leq 25 \Omega$
Overload	$\leq 30 \text{ V}$	$\leq 100 \text{ mA}$
Modbus		
Protocol	Modbus RTU (RS485)	
Module addressing	1 to 247	
Baud rate	300, 600, 1200, 2400, 4800, 9600, 19200, 38400, 57600, 115200	
Configuration	Parity: Even, Odd, None 2 stop bits, None 1 stop bit	Response delay: 1 to 1000 ms
Connectivity	Up to 247 DRAGO Modbus devices without additional repeater (1/8 Load)	
General Data		
Measuring error	$< 0.1 \%$ full scale	
Temperature coefficient ¹⁾	$< 100 \text{ ppm/K}$	
Resolution	14 bit	
Test voltage	3 kV AC, 50 Hz, 1 min. All channels against each other and against Modbus/power supply	
Working voltage ²⁾ (Basic insulation)	600 V AC/DC for overvoltage category II and pollution degree 2 acc. to EN 61010-1	
Protection against dangerous body currents ¹⁾	Protective Separation by reinforced insulation acc. to DIN EN 61010-1 up to 300 V AC/DC for overvoltage category II and contamination class 2 between input and Modbus/power supply	
Ambient temperature	Operation: $-25 \text{ }^\circ\text{C}$ to $+70 \text{ }^\circ\text{C}$ (-13 to $+158 \text{ }^\circ\text{F}$) Transport and storage: -40 to $85 \text{ }^\circ\text{C}$ (-40 to $+185 \text{ }^\circ\text{F}$)	
Power supply	24 V DC	voltage range 16.8 V to 31.2 V DC, max. 1.0 W
EMC ²⁾	EN 61326-1	
Construction	6.2 mm (0.244") housing, protection type: IP 20, mounting on 35 mm DIN rail acc. to EN 60715	
Weight	Approx. 70 g	

1) Average TC related to full scale value in specified operating temperature range, reference temperature 23 °C

2) For applications with high working voltages, ensure there is sufficient spacing or isolation from neighboring devices and protection against electric shocks.

3) Minor deviations possible during interference

Dimensions

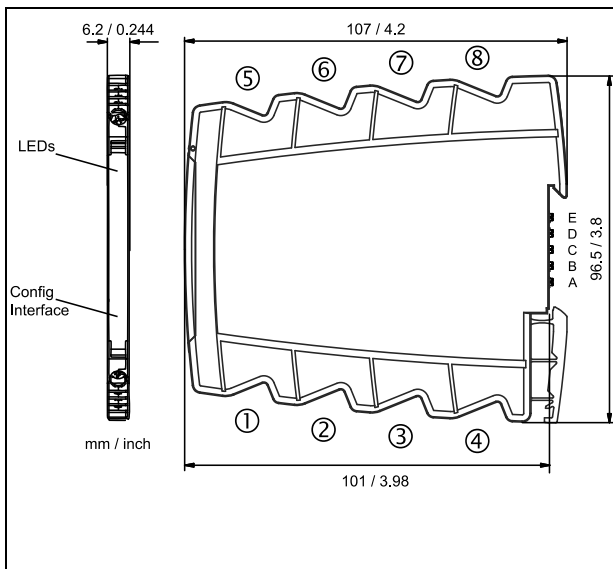

Subject to change!

Terminal assignments

1	+ U	- I	Channel 1
2	- U	+ I	
3	+ U	- I	Channel 2
4	- U	+ I	
5	+ U	- I	Channel 3
6	- U	+ I	
7	+ U	- I	Channel 4
8	- U	+ I	
A	Modbus A		
B	Modbus B		
C	- Power supply		
D	+ Power supply		

Connection

Captive plus-minus clamp screws
 Wire cross-section 0.5 to 2.5 mm² / AWG 20-14
 Stripped length 8 mm / 0.3 in
 Screw terminal torque 0.6 Nm / 5 lbf in
 Optional power connection via In-Rail-Bus (see accessories)

Product line

Device	Order No.
Modbus 4 Channel AI Module	DMB 96200 B

4 Channel 2AI/2AO Module

DMB 96400

4 Fully Isolated Analog I/O Channels, Modbus RTU

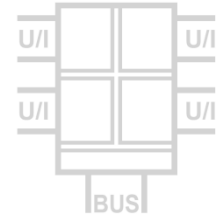

The Modbus 4 Channel Analog Module provides four fully isolated, independently configurable channels.

Two inputs can be configured as current or voltage inputs. In addition, these can be configured as digital inputs or digital outputs (open collector).

Two outputs can be configured as current or voltage outputs. In addition, these can be configured as digital outputs (active logic 0/10 V).

All parameters can be set via the Modbus RTU interface and via a programming socket behind the front panel. A free PC configuration software also offers extended setting options and extensive diagnostic functions during operation. A subset of the most common settings is also available via DIP switches.

The 5 port isolation ensures reliable decoupling of the channels from each other and from the processing circuit and the power supply. Power supply and Modbus RTU are connected via the rear-mounted In-Rail-Bus connection (see Accessories).

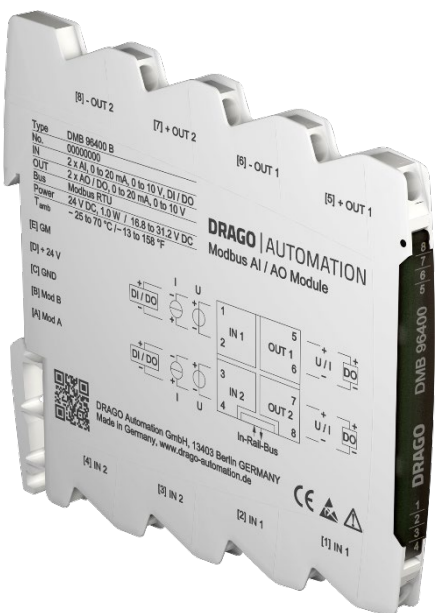

- **Processing of 4 industrial standard signals**
individually configurable as current or voltage signal
- **4 galvanic isolated I/O ports**
protection against erroneous measurements due to parasitic voltages or ground loops
- **Protective 5 port separation up to 300 V AC/DC**
Test voltage 3 kV
- **Fast signal acquisition**
high measuring rate, short processing times
- **In-Rail-Bus connector for Modbus and Power Supply**
allows fast and economical installation
- **Freely scalable**
up to 247 DRAGO Module in one Modbus segment
- **Extremely slim design**
6.2 mm slim housing for a simple and space saving DIN rail mounting
- **5 Years Warranty**
Defects occurring within 5 years from delivery date shall be remedied free of charge at our plant (carriage and insurance paid by sender)

Block diagram

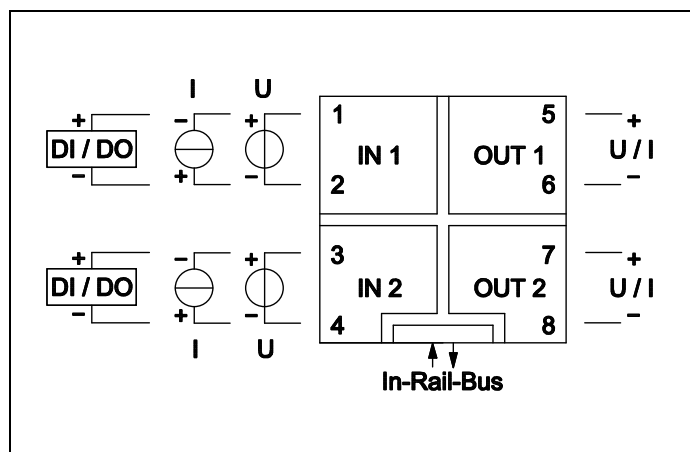



Technical Data

Input	Voltage	Current
Input signal	0 ... 10 V	0 ... 20 mA
Input resistance	≥ 100 kΩ	≤ 25 Ω
Overload	≤ 30 V	≤ 100 mA
Additional function	DI: 12/24 V (L < 2.0 V H > 8.4 V) DO: Open collector switching output, ≤ 30 V / ≤ 100 mA (drop voltage < 2V)	
Output	Voltage	Current
Output signal	0 ... 10 V	0 ... 20 mA
	0 to 20 mA	
Load	≤ 5 mA (2 kΩ at 10 V)	≤ 12 V (600 Ω at 20 mA)
Residual ripple	< 10 mVrms	
Additional function	DO: active switching output 0/10 V	
Modbus		
Protocol	Modbus RTU (RS485)	
Module addressing	1 to 247	
Baud rate	300, 600, 1200, 2400, 4800, 9600, 19200, 38400, 57600, 115200	
Configuration	Parity: Even, Odd, None 2 stop bits, None 1 stop bit	Response delay: 1 to 1000 ms
Connectivity	Up to 247 DRAGO Modbus devices without additional repeater (1/8 Load)	
General Data		
Measuring error	< 0.1 % full scale	
Temperature coefficient ¹⁾	< 100 ppm/K	
Resolution	14 bit	
Test voltage	3 kV AC, 50 Hz, 1 min. All channels against each other and against Modbus/power supply	
Working voltage ²⁾ (Basic insulation)	600 V AC/DC for overvoltage category II and pollution degree 2 acc. to EN 61010-1	
Protection against dangerous body currents ¹⁾	Protective Separation by reinforced insulation acc. to DIN EN 61010-1 up to 300 V AC/DC for overvoltage category II and contamination class 2 between input and Modbus/power supply	
Ambient temperature	Operation: -25 °C to +70 °C (-13 to +158 °F) Transport and storage: -40 to 85 °C (-40 to +185 °F)	
Power supply	24 V DC	voltage range 16.8 V to 31.2 V DC, max. 1.0 W
EMC ²⁾	EN 61326-1	
Construction	6.2 mm (0.244") housing, protection type: IP 20, mounting on 35 mm DIN rail acc. to EN 60715	
Weight	Approx. 70 g	

1) Average TC related to full scale value in specified operating temperature range, reference temperature 23 °C

2) For applications with high working voltages, ensure there is sufficient spacing or isolation from neighboring devices and protection against electric shocks.

3) Minor deviations possible during interference

Dimensions

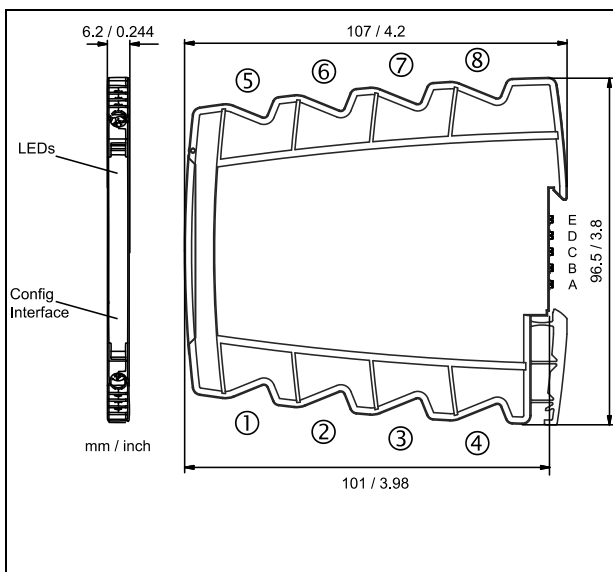

Terminal assignments

1	+ U	- I	Input 1
2	- U	+ I	Input 1
3	+ U	- I	Input 2
4	- U	+ I	Input 2
5	+ U	+ I	Output 1
6	- U	- I	Output 1
7	+ U	+ I	Output 2
8	- U	- I	Output 2
A	Modbus A		
B	Modbus B		
C	- Power supply		
D	+ Power supply		

Connection

Captive plus-minus clamp screws
Wire cross-section 0.5 to 2.5 mm² / AWG 20-14
Stripped length 8 mm / 0.3 in
Screw terminal torque 0.6 Nm / 5 lbf in
Optional power connection via In-Rail-Bus (see accessories)

Product line

Device	Order No.
Modbus 4 Channel 2AI/2AO Module	DMB 96400 B

Subject to change!

Universal AI/DI Module DMB 96500

Universal Measuring Input, Modbus RTU

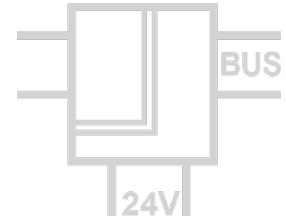

The Modbus Universal AI/DI Module is intended to be used with a wide range of industrial sensors.

All parameters can be set via the Modbus RTU interface and via a programming socket behind the front panel. A free PC configuration software also offers extended setting options and extensive diagnostic functions during operation. A subset of the most common settings is also available via DIP switches.

The measuring value can be read over the Modbus RTU (RS485) interface.

The 2-way isolation guarantees reliable decoupling of the sensor circuit from the Processing circuit and the auxiliary power circuit. Auxiliary power and Modbus RTU can be connected via the connection terminals or via the In-Rail-Bus connector (see accessories).

- High performance measuring input for all industrial sensors:
Pt, Ni, TC, KTY, mA, V, mV, Ω , Pot, Hz, PWM

- Uni-/Bipolar and TRMS capture of current and voltage

- Easy configurable by DIP switch or USB interface

- 15 programmable user-specific settings directly selectable via DIP switches

- Freely scalable up to 247 DRAGO modules in one Modbus segment

- Protective Separation up to 300 V AC/DC test voltage 3 kV

- Highest accuracy measuring resolution up to 24 bit

- In-Rail-Bus Connector for Modbus and Power Supply allows fast and economical installation

- Extremely slim only 6.2 mm installation width

- 5 Years Warranty Defects occurring within 5 years from delivery date shall be remedied free of charge at our plant (carriage and insurance paid by sender)



Block diagram

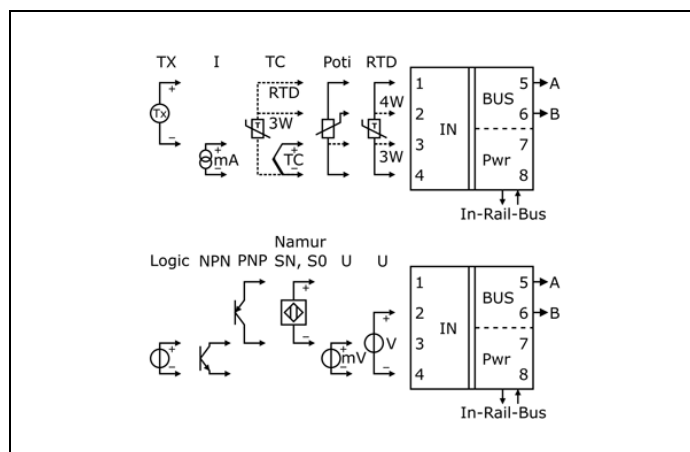

Technical Data

Input					
Sensor / input signal		Measuring error	TC ¹⁾	Sensor / input signal	
Pt100, Pt1000, JPt100		0.1 K + 0.05 % m.v.	0.02 K/°C	Ni100, Ni120, Ni200	0.1 K + 0.05 % m.v. 0.02 K/°C
Pt200		0.3 K + 0.05 % m.v.	0.02 K/°C	Ni500	0.5 K + 0.05 % m.v. 0.02 K/°C
Pt500, Pt2000, Pt1000 (IEC 60751), JPt50		0.2 K + 0.05 % m.v.	0.02 K/°C	Ni1000	0.25 K + 0.05 % m.v. 0.02 K/°C
KTY (66 types)		0.1 K + 0.05 % m.v.	0.02 K/°C		
Measuring rate Pt, Ni, KTY		4 /s			
Resistor / Pot 500Ω, 5kΩ, 20kΩ, 100kΩ		0.05 % full scale		100 ppm/K	
Measuring rate Resistor / Pot		25 /s			
Connection /Sensor current /Cable resistance		2-, 3-, 4-wire / 0.2 mA, 10 μA / < 100 Ω, programmable for 2-wire			
TC sensor type A, C, D, R, S		0.5 K + 0,08 % m.v.		0.1 K/°C	
TC sensor type B		0.5 K + 0,08 % m.v.		0.15 K/°C	
TC sensor type E, J, K, L, N, T, U		0.5 K + 0,08 % m.v.		0.05 K/°C	
Measuring rate		4 /s			
Cold junction compensation		internal, external Pt100 / PT1000, programmable, uncompensated			
Current ±1 mA, ±20 mA, ±100 mA		0.05 % full scale		100 ppm/K	
Voltage ±1 V, ±10 V, ±100 V, ±300 V		0.05 % full scale		100 ppm/K	
mV-Shunt ±50 mV, ±100 mV, ±500 mV		0.05 % full scale		100 ppm/K	
Measuring rate Current / Voltage		100 /s			
Input resistance		Voltage: > 100 kΩ, Current: < 55 Ω			
Measuring modes		DC, Average, RMS		Additional measuring error in RMS mode (40 Hz to 500 Hz): 2 % m.v.	
Frequency ≤ 1 Hz to ≤ 200 kHz		0.1 % full scale		100 ppm/K	
PWM ≤ 1 Hz to ≤ 10 kHz (1 to 99 %)		0.1 % full scale		100 ppm/K	
Input signal		NAMUR, SN, NPN, PNP, Push-Pull, SO-Switch type B			
Push-Pull level /NPN pullup /PNP pulldown		3.3 to 5 V / 3.2 kΩ / 11 kΩ, always active			

Modbus	
Protocol	Modbus RTU (RS485)
Module addressing	1 to 247
Baud rate	300, 600, 1200, 2400, 4800, 9600, 19200, 38400, 57600, 115200
Configuration	Parity: Even, Odd, None 2 stop bits, None 1 stop bit Response delay: 1 to 1000 ms
Connectivity	Up to 247 DRAGO Modbus devices without additional repeater (1/8 Load)

General Data	
Test voltage	3 kV AC, 50 Hz, 1 min., Input against Modbus/power supply
Working voltage ²⁾ (Basic insulation)	600 V AC/DC for overvoltage category II and pollution degree 2 acc. to EN 61010-1
Protection against dangerous body currents ²⁾	Protective Separation by reinforced insulation acc. to EN 61010-1 up to 300 V AC/DC for overvoltage category II and contamination class 2 between input and Modbus/power supply.
Ambient temperature	Operation: -25 °C to +70 °C Transport and storage: -40 °C to +85 °C
Power supply	24 V DC Voltage range 16.8 V to 31.2 V DC, max. 1.3 W
EMC ³⁾	EN 61326-1
Construction	6.2 mm (0.244") housing, protection type: IP 20, mounting on 35 mm DIN rail acc. to EN 60715
Weight	Approx. 70 g

1) Average TC in specified operating temperature range, given in units of display error [K] per change in ambient temperature [°C] Subject to change!
 2) For applications with high working voltages, ensure there is sufficient spacing or isolation from neighboring devices and protection against electric shocks.
 3) Minor deviations possible during interference

Dimensions

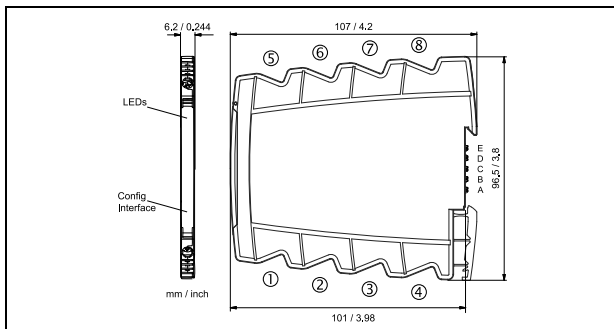

Terminal assignments

1	RTD / R / Pot / TX+ / NAMUR+
2	RTD / R / Pot / U+
3	RTD / R / Pot / TX- / I+ / TC+
4	RTD / R / Pot / U- / I- / TC-
5	Modbus A (connected to In-Rail-Bus A)
6	Modbus B (connected to In-Rail-Bus B)
7	+ Power supply (connected to In-Rail-Bus D)
8	- Power supply (connected to In-Rail-Bus C)

Connection

Captive plus-minus clamp screws
 Wire cross-section 0.5 ... 2.5 mm² / AWG 20-14
 Stripped length 8 mm / 0.3 in
 Screw terminal torque 0.6 Nm / 5 lbf in
 Optional power connection via In-Rail-Bus (see accessories)

Product line

Device	Order No.
Modbus Universal AI/DI Module	DMB 96500 B

4 Channel DI/DO Module DMB 96700

4 independent controllable digital I/O channels, Modbus RTU

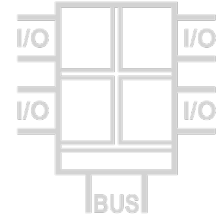

The Modbus 4-channel DI/DO module provides four independently configurable inputs/outputs. The inputs can be used either as a binary, frequency or counter input with three selectable input levels. The open collector outputs are usable as binary, frequency, pulse or PWM outputs. Various time functions can be used to set the switching behaviour.

All parameters can be set via the Modbus RTU interface and via a programming socket behind the front panel. A free PC configuration software also offers extended setting options and extensive diagnostic functions during operation. A subset of the most common settings is also available via DIP switches.

The 5 port isolation ensures reliable decoupling of the inputs/outputs from each other and from the processing circuit and the power supply. Power supply and Modbus RTU are connected via the rear-mounted In-Rail-Bus connection (see Accessories).

- **4 independent controllable Channels**
programmable as digital input or output
- **Extensive programmable operating functions**
programmable switch-ON and switch-OFF behavior
- **Protective 5 port separation up to 300 V AC/DC**
test voltage 3 kV
- **Status indication**
indication of operation status for each I/O channel
- **In-Rail-Bus Connector for Modbus and Power Supply**
allows fast and economical installation
- **Freely scalable**
up to 247 DRAGO modules in one Modbus segment
- **Extremely slim design**
6.2 mm slim housing for a simple and space saving DIN rail mounting
- **5 Years Warranty**
Defects occurring within 5 years from delivery date shall be remedied free of charge at our plant (carriage and insurance paid by sender)



Block diagram

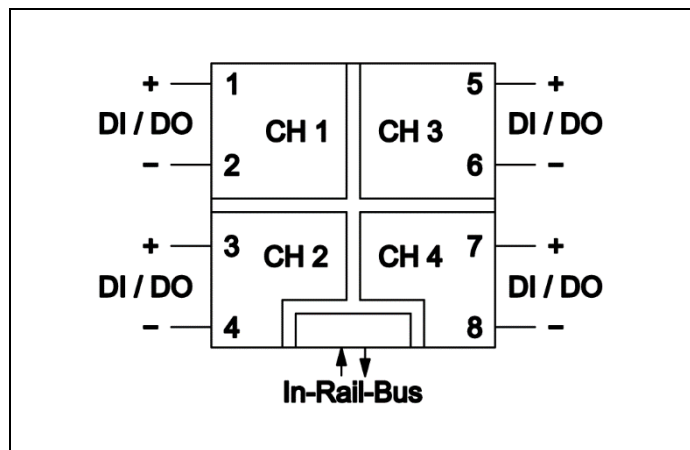



Technical Data

Input		
Input level	5 V, 12 V, 24 V	Input resistance: 4 kΩ
Input voltage	< 32 V DC	
Output		
Output type	Open collector	
Max. voltage / current	32 V DC, 100 mA	
Residual voltage	< 1.5 V DC	
Functions	Binary Frequency: 0.1 Hz to 1 kHz Counter: 16 / 32 Bit	Min. pulse width: 0.5 ms
Modbus		
Protocol	Modbus RTU (RS485)	
Module addressing	1 to 247	
Baud rate	300, 600, 1200, 2400, 4800, 9600, 19200, 38400, 57600, 115200	
Configuration	Parity: Even, Odd, None 2 stop bits, None 1 stop bit	Response delay: 1 to 1000 ms
Connectivity	Up to 247 DRAGO Modbus devices without additional repeater (1/8 Load)	
General Data		
Indication	Yellow LED for each channel on front panel	
Test voltage	3 kV AC, 50 Hz, 1 min. All channels against each other and against Modbus/power supply	
Protection against dangerous body currents ¹⁾	Protective Separation by reinforced insulation acc. to DIN EN 61010-1 up to 300 V AC/DC for overvoltage category II and contamination class 2 between input and Modbus/power supply	
Ambient temperature	Operation: -25 °C to +70 °C (-13 to +158 °F) Transport and storage: -40 °C to +85 °C (-40 to +185 °F)	
Power supply	24 V DC voltage range 16.8 V to 31.2 V DC, max. 0.5 W	
EMC ²⁾	EN 61326-1	
Construction	6.2 mm (0.244") housing, protection type: IP 20, mounting on 35 mm DIN rail acc. to EN 60715	
Weight	Approx. 70 g	

1) For applications with high working voltages, ensure there is sufficient spacing or isolation from neighboring devices and protection against electric shocks.

2) Minor deviations possible during interference

Dimensions

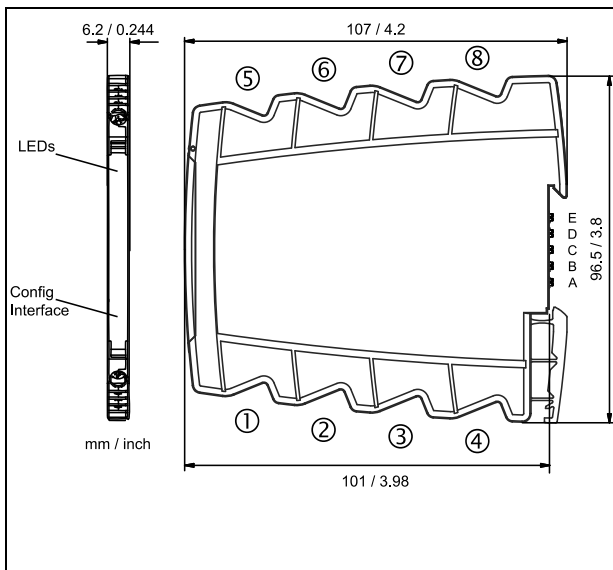

Subject to change!

Product line

Device	Order No.
Modbus 4 Channel DI/DO Module	DMB 96700 B

Terminal assignments

1	+ Channel 1
2	- Channel 1
3	+ Channel 2
4	- Channel 2
5	+ Channel 3
6	- Channel 3
7	+ Channel 4
8	- Channel 4
A	Modbus A
B	Modbus B
C	- Power supply
D	+ Power supply

Connection

Captive plus-minus clamp screws
Wire cross-section 0.5 ... 2.5 mm ² / AWG 20-14
Stripped length 8 mm / 0.3 in
Screw terminal torque 0.6 Nm / 5 lbf in
Optional power connection via In-Rail-Bus (see accessories)

4 Channel Relay Module

DMB 96800

4 independent power relays, Modbus RTU

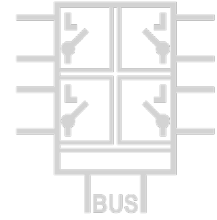

The Modbus 4-channel relay module can be used to switch four electrically isolated relays via a Modbus interface. Various time functions can be used to influence the switching behavior.

All parameters can be set via the Modbus RTU interface and via a programming socket behind the front panel. A free PC configuration software also offers extended setting options and extensive diagnostic functions during operation. A subset of the most common settings is also available via DIP switches.

The 5 port isolation guarantees reliable decoupling of the outputs from each other and from the processing circuit and the auxiliary power circuit. Power supply and Modbus RTU are connected via the rear-mounted In-Rail-Bus connection (see Accessories).

- **4 independent power relays**
250 V AC / 30 V DC / 2 A
- **Extensive programmable operating functions**
programmable switch-ON and switch-OFF behavior
- **Protective 5-way separation up to 300 V AC/DC**
Test voltage 3 kV
- **Status indication**
indication of operation status for each relay
- **In-Rail-Bus Connector for Modbus and Power Supply**
allows fast and economical installation
- **Freely scalable**
up to 247 DRAGO modules in one Modbus segment
- **Extremely slim design**
6.2 mm slim housing for a simple and space saving DIN rail mounting
- **5 Years Warranty**
Defects occurring within 5 years from delivery date shall be remedied free of charge at our plant (carriage and insurance paid by sender)



Block diagram

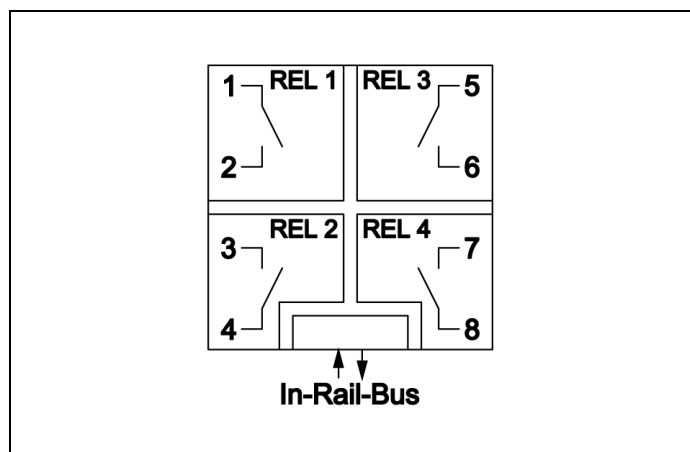

Technical Data

Output	
Relay 1, 2, 3, 4	250 V AC / 30 V DC / 2 A
Indication	Yellow LED for each channel on front panel

Modbus	
Protocol	Modbus RTU (RS485)
Module addressing	1 to 247
Response delay	1 to 1000 ms
Baud rate	300, 600, 1200, 2400, 4800, 9600, 19200, 38400, 57600, 115200
Configuration	Parity: Even, Odd, None 2 stop bits, None 1 stop bit
Connectivity	Up to 247 DRAGO Modbus devices without additional repeater (1/8 Load)
Indication	Yellow LED on front panel

General Data	
Test voltage	3 kV AC, 50 Hz, 1 Min. All relays against each other and against Modbus/power supply
Protection against dangerous body currents ¹⁾	Protective Separation by reinforced insulation acc. to DIN EN 61010-1 up to 300 V AC/DC for overvoltage category II and contamination class 2 between input and Modbus/power supply
Ambient temperature	Operation: -25 °C to +70 °C (-13 to +158 °F) Transport and storage: -40 °C to +85 °C (-40 to +185 °F)
Power supply	24 V DC Voltage range 16.8 V to 31.2 V DC, max. 0.7 W
EMC ²⁾	EN 61326-1
Construction	6.2 mm (0.244") housing, protection type: IP 20, mounting on 35 mm DIN rail acc. to EN 60715
Weight	Approx. 70 g

1) For applications with high working voltages, ensure there is sufficient spacing or isolation from neighboring devices and protection against electric shocks.

2) Minor deviations possible during interference

Dimensions

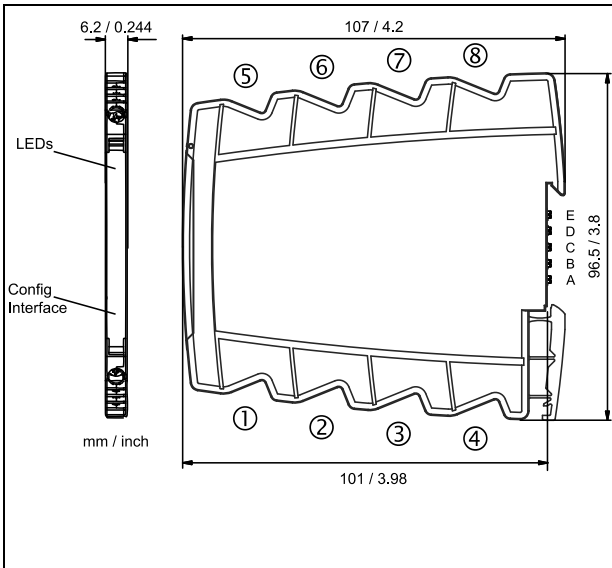

Subject to change!

Terminal assignments

1	Relay 1
2	Relay 1
3	Relay 2
4	Relay 2
5	Relay 3
6	Relay 3
7	Relay 4
8	Relay 4
A	Modbus A
B	Modbus B
C	- Power supply
D	+ Power supply

Connection

Captive plus-minus clamp screws
 Wire cross-section 0.5 ... 2.5 mm² / AWG 20-14
 Stripped length 8 mm / 0.3 in
 Screw terminal torque 0.6 Nm / 5 lbf in
 Optional power connection via In-Rail-Bus (see accessories)

Product line

Device	Order No.
Modbus 4 Channel Relay Module	DMB 96800 B

Our performance—your advantage

- Comprehensive product range
- Customer-specific special solutions
- Individual consulting and support
- Most modern production technology
- Certification according to ISO9001
- 5 years warranty
- Made in Germany

DRAGO Automation GmbH
Waldstrasse 86-90
13403 Berlin | Germany
Phone +49 - 30 - 40 99 82 0
info@drago-automation.de
www.drago-automation.de