

Universal AI/DI Module DMB 96500

Universal Measuring Input, Modbus RTU

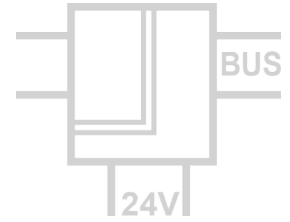

The Modbus Universal AI/DI Module is intended to be used with a wide range of industrial sensors.

All parameters can be set via the Modbus RTU interface and via a programming socket behind the front panel. A free PC configuration software also offers extended setting options and extensive diagnostic functions during operation. A subset of the most common settings is also available via DIP switches.

The measuring value can be read over the Modbus RTU (RS485) interface.

The 2-way isolation guarantees reliable decoupling of the sensor circuit from the Processing circuit and the auxiliary power circuit. Auxiliary power and Modbus RTU can be connected via the connection terminals or via the In-Rail-Bus connector (see accessories).

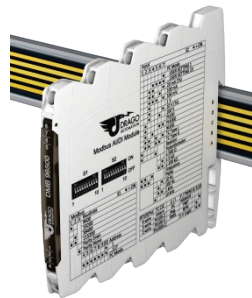

- **High performance measuring input for all industrial sensors:**
Pt, Ni, TC, KTY, mA, V, mV, Ω , Pot, Hz, PWM
- **Uni-/Bipolar and TRMS capture** of current and voltage
- **Easy configurable** by DIP switch or USB interface
- **15 programmable user-specific settings** directly selectable via DIP switches
- **Freely scalable** up to 247 DRAGO modules in one Modbus segment
- **Protective Separation up to 300 V AC/DC** test voltage 3 kV
- **Highest accuracy** measuring resolution up to 24 bit
- **In-Rail-Bus Connector for Modbus and Power Supply** allows fast and economical installation
- **Extremely slim** only 6.2 mm installation width
- **5 Years Warranty**
Defects occurring within 5 years from delivery date shall be remedied free of charge at our plant (carriage and insurance paid by sender)

Block diagram

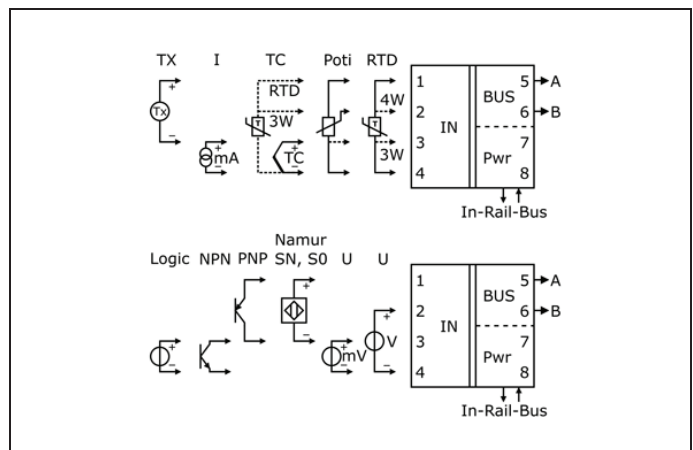

Technical Data

Input

Sensor / input signal	Measuring error	TC ¹⁾	Sensor / input signal	Measuring error	TC ¹⁾
Pt100, Pt1000, JPt100	0.1 K + 0.05 % m.v.	0.02 K/°C	Ni100, Ni120, Ni200	0.1 K + 0.05 % v.M.	0.02 K/°C
Pt200	0.3 K + 0.05 % m.v.	0.02 K/°C	Ni500	0.5 K + 0.05 % v.M.	0.02 K/°C
Pt500, Pt2000, Pt1000 (IEC 60751), JPt50	0.2 K + 0.05 % m.v.	0.02 K/°C	Ni1000	0.25 K + 0.05 % v.M.	0.02 K/°C
KTY (66 types)	0.1 K + 0.05 % m.v.	0.02 K/°C			
Measuring rate Pt, Ni, KTY	4 /s				
Resistor / Pot 500Ω, 5kΩ, 20kΩ, 100kΩ	0.05 % v.E.		100 ppm/K		
Measuring rate Resistor / Pot	25 /s				
Connection /Sensor current /Cable resistance	2-, 3-, 4-wire / 0.2 mA, 10 μA / < 100 Ω, programmable for 2-wire				
TC sensor type A, C, D, R, S	0.5 K + 0,08 % m.v.		0.1 K/°C		
TC sensor type B	0.5 K + 0,08 % m.v.		0.15 K/°C		
TC sensor type E, J, K, L, N, T, U	0.5 K + 0,08 % m.v.		0.05 K/°C		
Measuring rate	4 /s				
Cold junction compensation	internal, external Pt100 / PT1000, programmable, uncompensated				
Current ±1 mA, ±20 mA, ±100 mA	0.05 % full scale		100 ppm/K		
Voltage ±1 V, ±10 V, ±100 V, ±300 V	0.05 % full scale		100 ppm/K		
mV-Shunt ±50 mV, ±100 mV, ±500 mV	0.05 % full scale		100 ppm/K		
Measuring rate Current / Voltage	100 /s				
Input resistance	Voltage: > 100 kΩ, Current: < 55 Ω				
Measuring modes	DC, Average, RMS		Additional measuring error in RMS mode (40 Hz to 500 Hz): 2 % m.v.		
Frequency ≤ 1 Hz to ≤ 200 kHz	0.1 % full scale		100 ppm/K		
PWM ≤ 1 Hz to ≤ 10 kHz (1 to 99 %)	0.1 % full scale		100 ppm/K		
Input signal	NAMUR, SN, NPN, PNP, Push-Pull, SO-Switch type B				
Push-Pull level /NPN pullup /PNP pulldown	3.3 to 5 V / 3.2 kΩ / 11 kΩ, always active				

Modbus

Protocol	Modbus RTU (RS485)
Module addressing	1 to 247
Baud rate	300, 600, 1200, 2400, 4800, 9600, 19200, 38400, 57600, 115200
Configuration	Parity: Even, Odd, None 2 stop bits, None 1 stop bit Response delay: 1 to 1000 ms
Connectivity	Up to 247 DRAGO Modbus devices without additional repeater (1/8 Load)

General Data

Test voltage	3 kV AC, 50 Hz, 1 min., Input against Modbus/power supply	
Working voltage ²⁾ (Basic insulation)	600 V AC/DC for overvoltage category II and pollution degree 2 acc. to EN 61010-1	
Protection against dangerous body currents ²⁾	Protective Separation by reinforced insulation acc. to EN 61010-1 up to 300 V AC/DC for overvoltage category II and contamination class 2 between input and Modbus/power supply.	
Ambient temperature	Operation: -25 °C to +70 °C	Transport and storage: -40 °C to +85 °C
Power supply	24 V DC	Voltage range 16.8 V to 31.2 V DC, max. 1.3 W
EMC ³⁾	EN 61326-1	
Construction	6.2 mm (0.244") housing, protection type: IP 20, mounting on 35 mm DIN rail acc. to EN 60715	
Weight	Approx. 70 g	

1) Average TC in specified operating temperature range, given in units of display error [K] per change in ambient temperature [°C]

Subject to change!

2) For applications with high working voltages, ensure there is sufficient spacing or isolation from neighboring devices and protection against electric shocks.

3) Minor deviations possible during interference

Dimensions

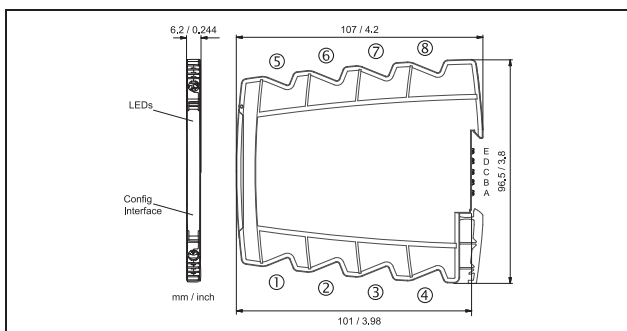

Terminal assignments

1	RTD / R / Pot / TX+ / NAMUR+	
2	RTD / R / Pot / U+	
3	RTD / R / Pot / TX- / I+ / TC+	
4	RTD / R / Pot / U- / I- / TC-	
5	Modbus A	(connected to In-Rail-Bus A)
6	Modbus B	(connected to In-Rail-Bus B)
7	+ Power supply	(connected to In-Rail-Bus D)
8	- Power supply	(connected to In-Rail-Bus C)

Connection

Captive plus-minus clamp screws
 Wire cross-section 0.5 ... 2.5 mm² / AWG 20-14
 Stripped length 8 mm / 0.3 in
 Screw terminal torque 0.6 Nm / 5 lbf in
 Optional power connection via In-Rail-Bus (see accessories)

Product line

Device	Order No.
Modbus Universal AI/DI Module	DMB 96500 B