

# Repeater Power Supply DC 52100

Powering and Isolation of  
2- and 3-wire Transmitters

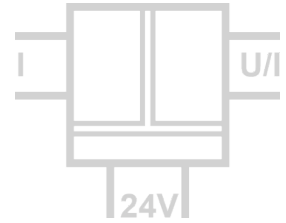

The repeater power supply DC 52100 is used to supply and separate 2- and 3-wire transmitters and active sensor signals.

The repeater power supply supplies the transmitter with power and transmits the current or voltage measuring signal with high accuracy galvanic isolated to the output. Alternative the measuring input accepts active signals from 4-wire transmitters.

The input and output range of DC 52100 can be easily set by using DIP switch. Due to the calibrated range selection no further adjustment is necessary.

The auxiliary power can be supplied via the connection terminals or via the optional In-Rail-Bus connector. A green LED on the front of the unit has been provided to monitor the power supply.

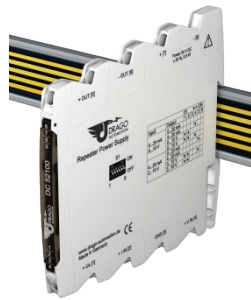

- **Universal operation of Transmitters**  
Energization and separation of field located 2-, 3- and 4-wire transmitters with current or voltage output
- **Calibrated signal setting via DIP switch**  
Input and output range can be set by using DIP switch - high precision without any further adjustment
- **3-Port isolation**  
Protection against erroneous measurements due to parasitic voltages or ground loops
- **Extremely slim design**  
6.2 mm slim housing for a simple and space saving DIN rail mounting
- **Optional In-Rail-Bus mounting rail connector**  
allows for fast and economical installation
- **Protective Separation acc. to EN 61140**  
Protects service personnel and downstream devices against impermissibly high voltage
- **5 Years Warranty**  
Defects occurring within 5 years from delivery date shall be remedied free of charge at our plant (carriage and insurance paid by sender)

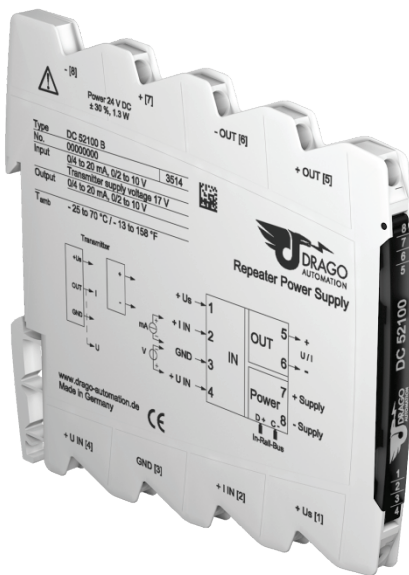

## Block diagram

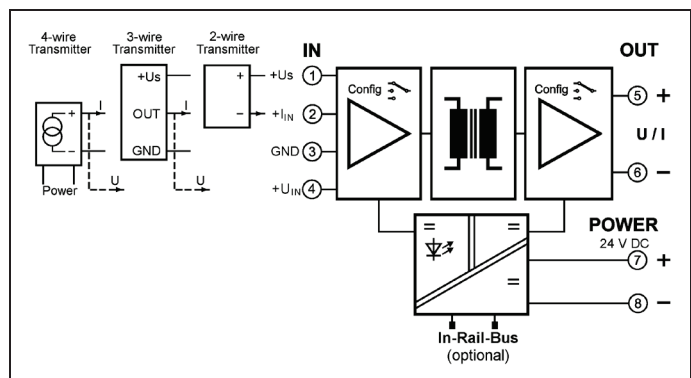

### Technical Data

Input	
Input signal (calibrated switchable)	0 ... 20 mA    4 ... 20 mA    0 ... 10 V    2 ... 10 V
Input resistance	Current input $\leq 25 \Omega$ Voltage input $\geq 100 k\Omega$
Overload	50 mA / 30 V
Transmitter supply (Tx)	17 V (open circuit voltage/short circuit current $< 22 V/35 mA$ )
Output	
Output signal (calibrated switchable)	0 ... 20 mA    4 ... 20 mA    0 ... 10 V    2 ... 10 V
Load	Current output: $\leq 12 V (600 \Omega \text{ at } 20 mA)$ Voltage output: $\leq 5 mA (2 k\Omega \text{ at } 10 V)$
Linear transmission range	-1 ... +110 %
Residual ripple	$< 10 mV_{rms}$
General Data	
Transmission error	$< 0.1 \%$ full scale
Temperature coefficient <sup>1)</sup>	$< 100 ppm/K$
Cut-off frequency -3 dB (switchable)	5 kHz    100 Hz
Response time $T_{99}$	150 $\mu s$ 7 ms
Test voltage	3 kV AC, 50 Hz, 1 min.    Input against output against power supply
Working voltage <sup>2)</sup> (Basic Insulation)	600 V AC/DC for overvoltage category II and pollution degree 2 acc. to EN 61010-1
Protection against electrical shock <sup>2)</sup>	Protective separation according to EN 61140 by reinforced insulation in accordance with EN 61010 -1 up to 300 V AC/DC for overvoltage category II and pollution degree 2
Ambient temperature	Operation    -25 °C to +70 °C    (-13 to +158 °F) Transport and storage    -40 °C to +85 °C    (-40 to +185 °F)
Power supply	24 V DC    voltage range 16.8 V ... 31.2 V DC, approx. 1.3 W
EMC <sup>3)</sup>	EN 61326-1
Approvals	ATEX    DEMKO 16 ATEX 1685X $\text{Ex II 3 G Ex nA IIC T4 Gc}$ IECEX    IECEX UL 16.0055X    Ex nA IIC T4 Gc UL    E478692 USA/Canada    Class I, Division 2 Groups A, B, C, D T4
Construction	6.2 mm (0.244") housing, protection class IP 20, mounting on 35 mm DIN rail acc. to EN 60715
Weight	Approx. 70 g

1) Average TC related to full scale value in specified operating temperature range, reference temperature 23 °C

2) For applications with high working voltages, ensure there is sufficient spacing or isolation from neighboring devices and protection against electric shocks.

3) Minor deviations possible during interference

### Dimensions

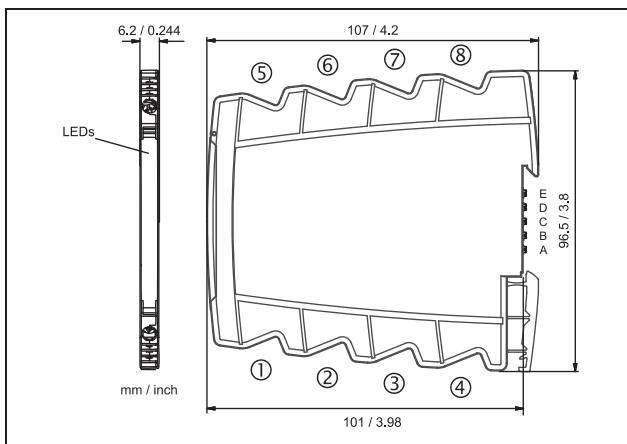

Subject to change!

### Terminal assignments

- |   |   |
|---|---|
| 1 | + Transmitter supply voltage $U_{Tx}$       |
| 2 | + Input current                             |
| 3 | - Input GND                                 |
| 4 | + Input voltage                             |
| 5 | + Output                                    |
| 6 | - Output                                    |
| 7 | + Power supply (connected to In-Rail-Bus D) |
| 8 | - Power supply (connected to In-Rail-Bus C) |

### Connection

- |   |
|---|
| Captive plus-minus clamp screws                             |
| Wire cross-section 0.5 ... 2.5 mm <sup>2</sup> / AWG 20-14  |
| Stripped length 8 mm / 0.3 in                               |
| Screw terminal torque 0.6 Nm / 5 lbf in                     |
| Optional power connection via In-Rail-Bus (see accessories) |

### Product line

Device	Order No.
Repeater Power Supply, calibrated range selection	DC 52100 S
Repeater Power Supply, calibrated range selection, In-Rail-Bus for power supply	DC 52100 B